

**DO NOT RETURN PRODUCT TO THE STORE**  
Individual stores do not stock parts.

**NO REGRESAS ESTA PRODUCTO A LA TIENDA**  
Las tiendas no tiene partes.

**NE RETOURNEZ PAS LE PRODUIT AU MAGASIN**  
Les magasins individuels ne gardent pas de pièces.

If a part is missing or damaged, call our toll-free customer service line. We will gladly ship your replacement parts FREE of charge.

Si falta partes o las partes estan danados llame gratis a la servicio del cliente. Con gusto mandamos las partes. Sin alguno carga.

Si une pièce manque ou est endommagée, appelez notre numéro de téléphone sans frais pour assistance à la clientèle. Nous enverrons avec plaisir les pièces de rechange sans frais.

Need Parts or Assistance?

Nesacitas partes o Asistencia?

Besoin de pièces ou d'assistance?

1-800-489-3351

or access our website

o visitar la pagina del internet  
ou accédez notre site web

© www.altrafurniture.com

For prompt, reliable service please have your assembly manual ready.  
Para servicio mas rapido y reliable por favor tenga esta manual listo.  
Pour un service rapide et fiable, s'il vous plait ayez votre livret d'assemblage en main.

**KEEP FOR REFERENCE**  
**GUARDAR PARA REFERENCIA**  
**GARDEZ POUR RÉFÉRENCE**



## ⚠ WARNING



Unit can tip over causing severe injury or death.

- Anchor unit to stud or wall.
- **DO NOT** allow children to climb on unit.
- Put heavy items on lower shelves or drawers.
- Open one drawer at a time.
- Read and follow all assembly instructions.

## ⚠ AVISO

*Este mueble puede caerse por encima causando daño serio o la muerte.*

- Anclar el mueble a un esparrago o al muro.
- **NO** dejar que los niños suben por encima del mueble.
- Poner los artículos mas pesados en los tableros o cajones inferiores.
- Abrir un cajon a la vez.
- Leer y seguir todos de los instrucciones para el montaje.

## ⚠ AVIS

*L'unité peut basculer et causer de blessures graves ou la mort.*

- Fixez l'unité au mur ou à un montant.
- **Ne PAS** laisser les enfants grimper sur l'unité.
- Déposez les articles lourds sur les tablettes ou dans les tiroirs du bas.
- Ouvrir un tiroir à la fois.
- Lire et suivre toutes les instructions d'assemblage.

### Thank you for purchasing from Ameriwood

If you need parts or assistance with our Ameriwood product, DO NOT return the unit to the store. Our staff is ready to provide you with prompt reliable service. If replacement parts are needed, call our toll-free number.

For quicker service, please have your instruction sheet available. The missing or defective part will be shipped free of charge.

Ameriwood produces each piece of its furniture with total customer satisfaction in mind. However, we realize that occasionally mistakes are made. To back our commitment, each new piece of furniture is covered by our 1 year warranty. This coverage includes the replacement of parts which may be missing or defective.

### Limited 1 Year Warranty

Ameriwood warrants this product to be free from defects in material and workmanship and agrees to remedy any such defect. This warranty covers one year from the date of original purchase. This is solely limited to the repair or replacement of defective furniture components and no assembly labor is included.

This warranty does not apply to any product which has been improperly assembled, subjected to misuse or abuse or which has been altered or repaired in any way. Liability for consequential damages is excluded to the extent exclusion is permitted by law. This warranty gives you specific legal rights. Additional warranty rights may be provided by law in some areas.

To obtain warranty service, purchaser must present original bill of sale. Components repaired or replaced are warranted through the remainder of the original warranty period only. The defective components will be repaired or replaced without charge, subject to the terms and conditions described above.

### Gracias por haber comprado de Ameriwood.

Si tienen falta de piezas o ayuda en respecto de este producto de Ameriwood, favor de no devolver este producto al almacén. Nuestro departamento de servicio tiene mucho orgullo en darle ayuda en la manera mas eficiente y lo pronto posible. Si es necesario de obtener piezas de repuesto, favor de llamar nuestro número de telefono.

Para servicio mas rapido, favor de tener el manual de montaje disponible. La pieza extraviada o defectuosa sera respuesta.

Ameriwood fabrica cada pieza de mueble con la satisfaccion del cliente en mente. Por mucho cuidado que tengamos de ver en cuando cometemos errores. Para apoyar nuestro compromiso, cada nueva pieza de mueble esta cubierta por nuestra garantia limitada de 1 año. En esta cobertura estan incluidas las piezas de repuesto para las piezas extraviadas o defectuosas.

### Garantía Limitada de 1 Año

Ameriwood le garantiza que este producto sera libre de los defectos de material o de construcción y esta de acuerdo a corregir esos defectos. Esta garantía entra en vigor al día de compra y dura uno año. Esta garantía es limitada solo en la reparación o reemplazo de las piezas defectuosas y el montaje de mano de obra no esta incluido.

Esta garantía no se aplica al producto que esta armado incorrectamente, maltratado o abusado de cualquier manera o que fue alterado o reparado de cualquier manera. La responsabilidad por los daños consiguientes es excluida hasta el punto que la exclusión es permitida por la ley. Esta garantía le da derechos legales especificos. Derechos de garantía suplementarios pueden ser suministrados por la ley en ciertas regiones.

Para obtener el servicio de garantía, el comprador debe presentar la factura de venta original. Las piezas reparadas o reemplazadas quedan garantizadas solo por el periodo de garantía original. Las piezas defectuosas serán reparadas o reemplazadas sin cargo sujeta a las condiciones estipuladas antedichas.

### Merci d'acheter de Ameriwood.

Si vous avez besoin de pièces ou d'assistance avec notre produit Ameriwood, ne retournez pas l'unité au magasin. Notre personnel est fier de vous offrir un service rapide et courtois. Si des pièces de remplacement sont requises, appelez notre numéro sans frais.

Pour un service plus rapide, s'il vous plaît ayez en main votre livret d'instruction. La pièce manquante ou défectueuse, sera expédiée gratuitement.

Ameriwood produit chaque morceau de son mobilier avec la satisfaction totale du client en tête. Cependant, nous réalisons que parfois des erreurs sont faites. Pour soutenir notre engagement, chaque nouvelle pièce de meuble est couverte par notre garantie de 1 an. Cette couverture inclut le remplacement de pièces qui peuvent être manquantes ou défectueuses.

### Garanti 1 an Limité

Ameriwood garantit ce produit libre de défauts de matériel ou de fabrication et consent à remédier à tout défaut. Cette garantie couvre un année à partir de la date originale d'achat. Cela est limité à la réparation ou au remplacement de composants du mobilier défectueux et n'inclut aucune main-d'oeuvre d'assemblage.

Cette garantie ne s'applique pas à tout produit qui a été assemblé de façon incorrecte, assujéti à des traitement rugueux soit abusifs ou modifié ou réparé d'aucune façon. La responsabilité pour les dégâts importants est exclue à l'exclusion de l'ampleur autorisée par loi. Cette garantie vous donne des droits légaux spécifiques. Les droits de garantie supplémentaires peuvent être fournis par la loi dans quelques régions.

Pour obtenir le service de la garantie, l'acheteur doit présenter l'acte de vente original. Les composants qui sont réparés ou remplacés, sont garantis seulement à travers le reste de la période de la garantie originale. Les composants défectueux seront réparés ou seront remplacés sans frais, sujets aux termes et conditions décrites au-dessus.

### HELPFUL HINTS - NOTITAS UTILES - LES ALLUSIONS UTILES

- Make sure all parts are included. *Asegurar que todas las piezas son incluidas. Assurez-vous que toutes les pièces sont incluses.*



- Read each step carefully before starting. It is very important that each step of instruction is performed in the correct order. If these steps are not followed in sequence, assembly difficulties will occur. *Leer con cuidado cada paso antes de empezar. Es muy importante de ejecutar cada paso en el orden correcto. Si los paso no estan ejecutados en secuencia, ocurrira dificultades en el montaje. Lisez chaque étape avec soin avant de commencer. C'est très important que chaque étape d'instruction est exécuté dans l'ordre correct. Si ces étapes ne sont pas suivies dans l'ordre, des difficultés d'assemblage se produiront.*

- Work in spacious area, preferably on a carpet. *Trabajar en una area espaciosa, preferiblemente sobre una alfombra. Travaillez dans un endroit spacieux, sur une moquette de préférence.*

- Have the following tools close at hand. *Tener las herramientas siguientes cerca de la mano. Ayez à portez de la main les outils suivants.*



- To clean product, use your favorite furniture polish and a soft cloth. DO NOT USE harsh chemicals or abrasive cleaners.

*Para limpiar el producto, utilizar la cera de lustrar para mueble y un trapo suave. NO UTILIZAR productos con químicos duros o abrasivos.*

*Pour nettoyer le produit, utilisez votre cire de mobilier favorite et un chiffon doux. N'UTILISEZ PAS de produits chimiques abrasifs*

- Most board parts are labeled or stamped on the raw edge. *Tienen las etiquetas o los sellos en el lado sin acabado.*

*La plupart des panneaux sont étiquetés ou stampés sur le côté non-laminé.*

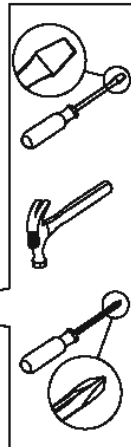

### AMERIWOOD CUSTOMER SERVICE SERVICIO A LA CLIENTELA DE AMERIWOOD LE SERVICE\* APRÈS-VENTE AMERIWOOD



Call us at:  
*Llamar a:*  
*Téléphonez à:*

1-800-489-3351  
(in U.S.A. only)



*or (0/00)*

FAX:

1-636-745-1005



Visit our website:  
*Visite nuestro website:*  
*Visitez notre site web:*

www.altrafurniture.com

*or (0/00)*

Write to:  
*Escribir a:*  
*Écrivez à:*

AMERIWOOD  
P.O. Box 346  
Wright City, MO 63390 USA  
Attention: Service Dept.

Monday - Friday  
7:00 am - 8:00 pm  
Central Time

Saturday  
9:00 am - 5:00 pm  
Central Time

Lunes - Viernes  
7:00 am - 8:00 pm  
Tiempo Central

Sabado  
9:00 am - 5:00 pm  
Tiempo Central

Lundis - Vendredis  
7:00h - 20:00h  
Heure Central

Samedi  
9:00h - 17:00h  
Heure Central

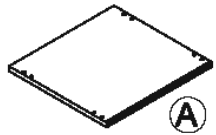

**Top**  
Panel superior  
DESSUS  
T9511096010

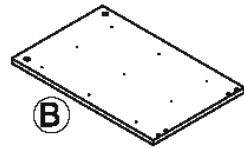

**Left Side Panel**  
Panel izquierdo  
PANNEAU GAUCHE  
T9511096020

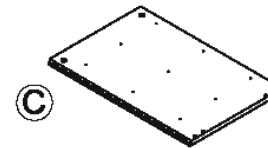

**Right Side Panel**  
Panel lateral derecho  
PANNEAU DROIT  
T9511096030



**Bottom Panel**  
Panel base  
PANNEAU INFÉRIEUR  
T9511096040



**3 Drawer Front Panel**  
Panel frontal del cajón 3  
PANNEAU AVANT DE TIROIR 3  
T9511096050

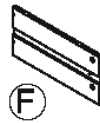

**3 Drawer Side (Left)**  
Lado del cajón 3  
CÔTÉ DE TIROIR 3  
T9511096060



**3 Drawer Side (Right)**  
Lado del cajón 3  
CÔTÉ DE TIROIR 3  
T9511096070



**3 Drawer Back**  
Panel trasero del cajón 3  
DOS DE TIROIR 3  
T9511096080



**3 Drawer Bottom**  
Fondo del cajón 3  
FOND DE TIROIR 3  
T9511096090



**Back Panel**  
Panel trasero  
PANNEAU ARRIÈRE  
T9511096100



**4 Foot**  
Pie 4  
PIED 4  
T9511096110



B34951109600



Ø15x12.5

① X 8

Cam Lock  
Tornillo de cerdura  
Serrure de la came  
THX5101

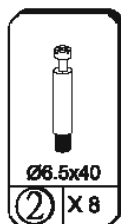

Ø6.5x40

② X 8

Cam Bolt  
Tornillo de rosca  
Verrou de la came  
THX5201

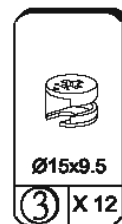

Ø15x9.5

③ X 12

Cam Lock  
Tornillo de cerdura  
Serrure de la  
came THX5102

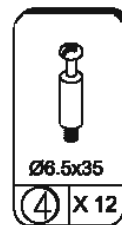

Ø6.5x35

④ X 12

Cam Bolt  
Tornillo de rosca  
Verrou de la camen  
THX5202

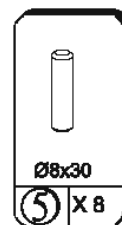

Ø8x30

⑤ X 8

Wood Dowel  
Clavija de madera  
GOUJON EN BOIS  
THX8201

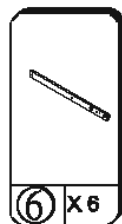

⑥ X 6

Slide  
Deslizante  
COULISSANTE  
THX2101



Ø4x12

⑦ X 6

Bolt  
Tornillo  
BOULON  
THX4121



Ø4x16

⑧ X 18

Flat Head Screw  
Tornillo de cabeza plana  
VIS À TÊTE PLATE  
THX4321

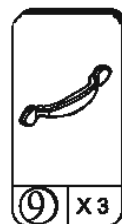

⑨ X 3

Knob  
Perilla  
POIGNÉE  
THX1101

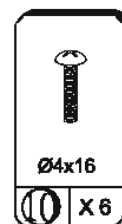

Ø4x16

⑩ X 6

Bolt  
Tornillo  
BOULON  
THX4116



Ø4x25

⑪ X 12

Pan Head Screw  
Tornillo de cabeza plana  
VIS À TÊTE RONDE  
THX4311



Ø3x16

⑫ X 14

Pan Head Screw  
Tornillo de cabeza plana  
VIS À TÊTE RONDE  
THX4312

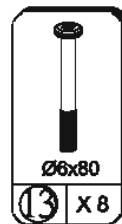

Ø6x80

⑬ X 8

Screw  
Tornillo  
VIS  
THX4180

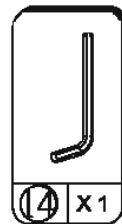

⑭ X 1

Hex Key  
Llave en L  
CLÉ HEXAGONALE  
THX7101



⑮ X 1

GREEN Plate  
Plaque GREEN  
PLACA GREEN  
TZJ0003

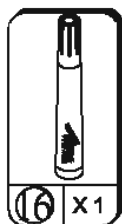

⑯ X 1

Marker  
Marcador  
Marqueur  
TFT0002

This illustration shows how the CAM fastening system works.

Esta ilustracion muestra el sistema de fijacion de leva y como funciona.

Cette illustration demontre le systeme de fixation et la facon qu'il fonctionne.

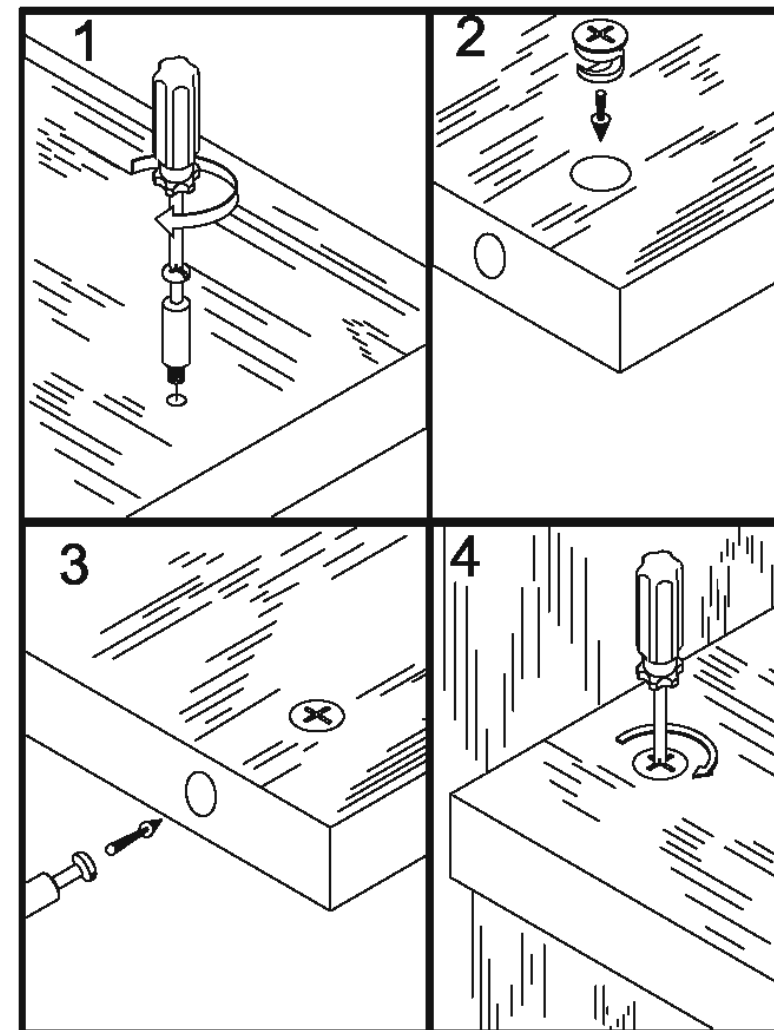

B34951109600

# 1

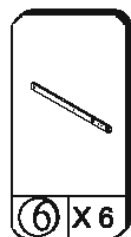
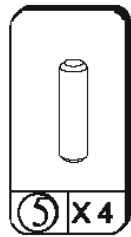
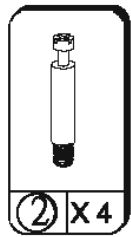
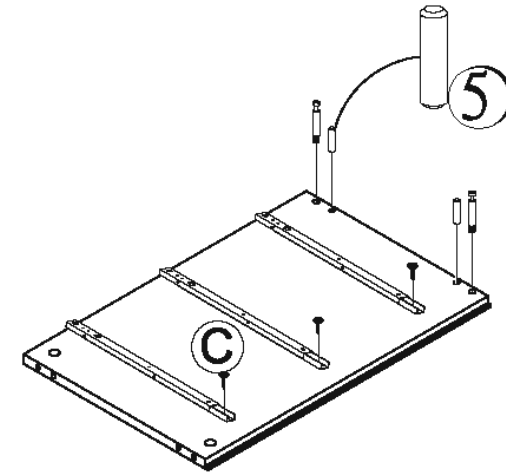
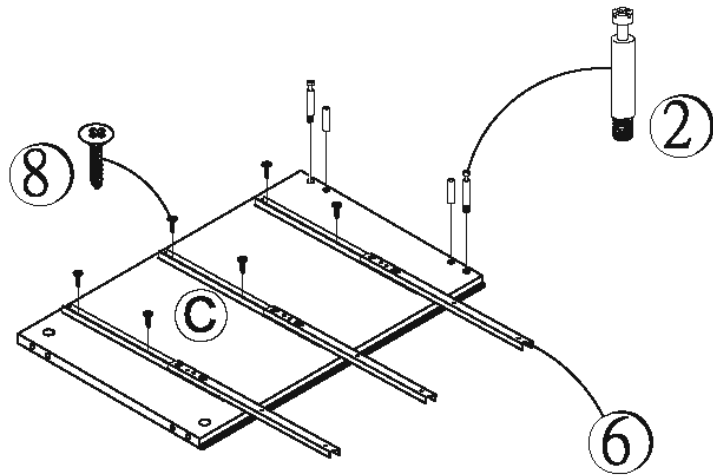
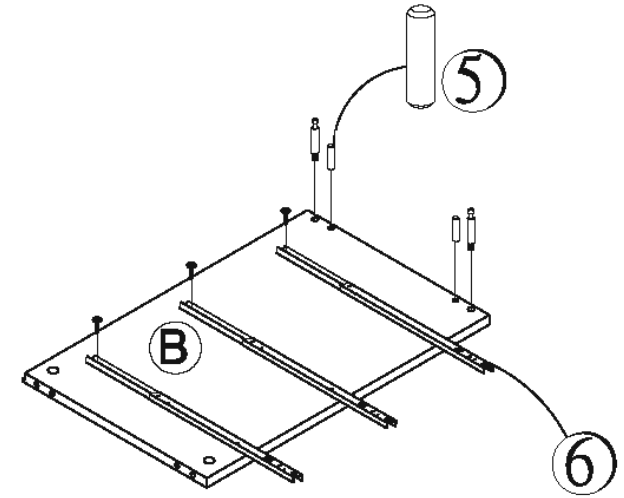
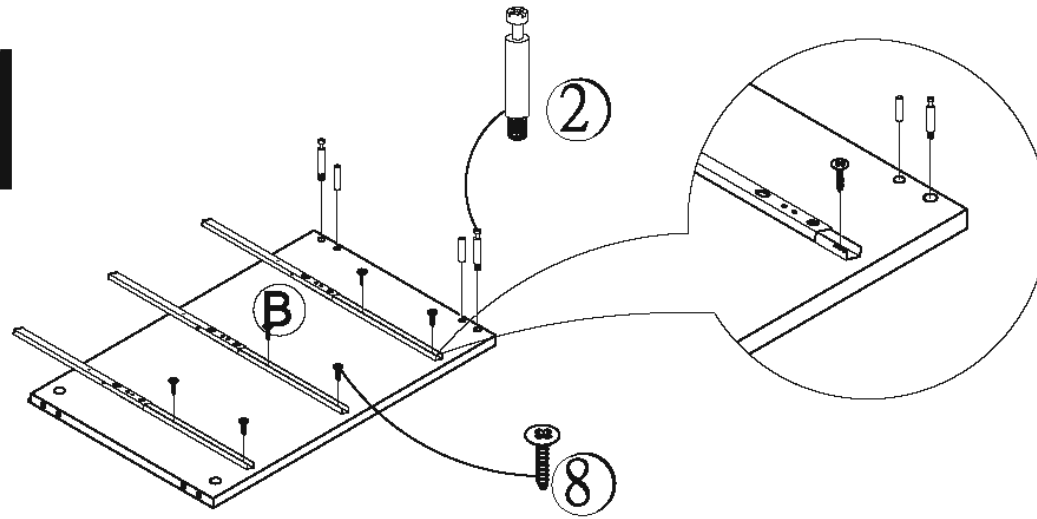

B34951109600

# 2

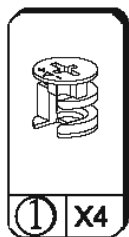
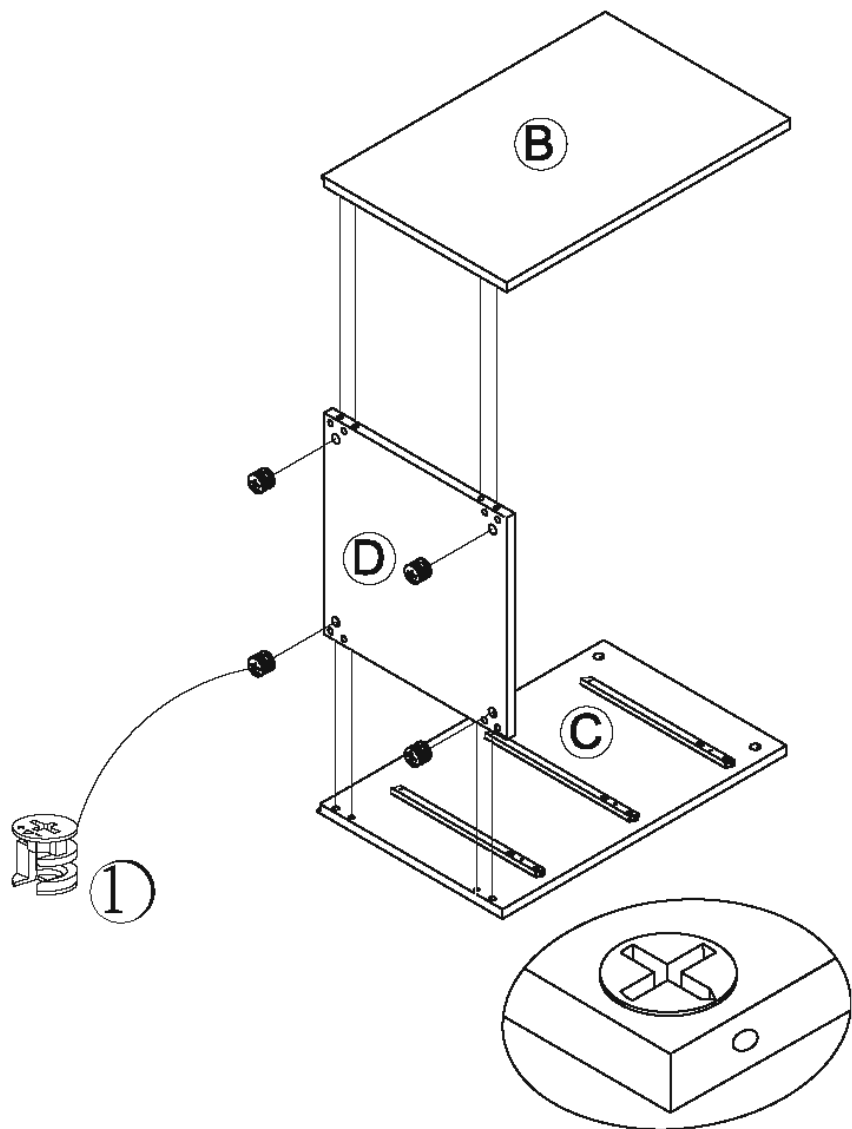

Proper orientation of CAM LOCK  
Orientacion propio del leva de cerradura  
La bonne position des cames

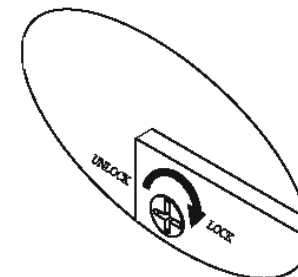

B34951109600

# 3

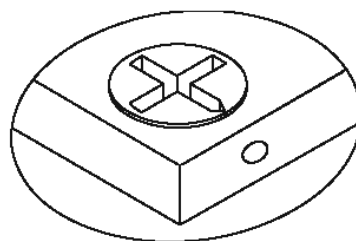
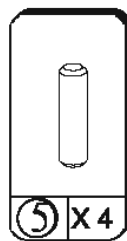
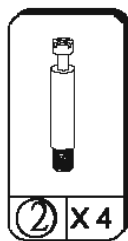
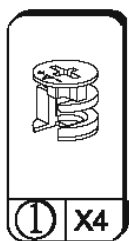
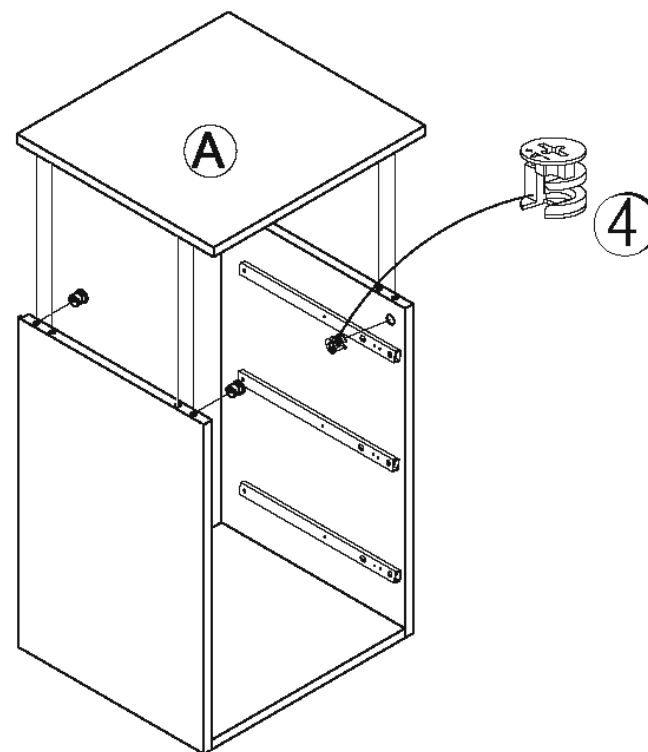
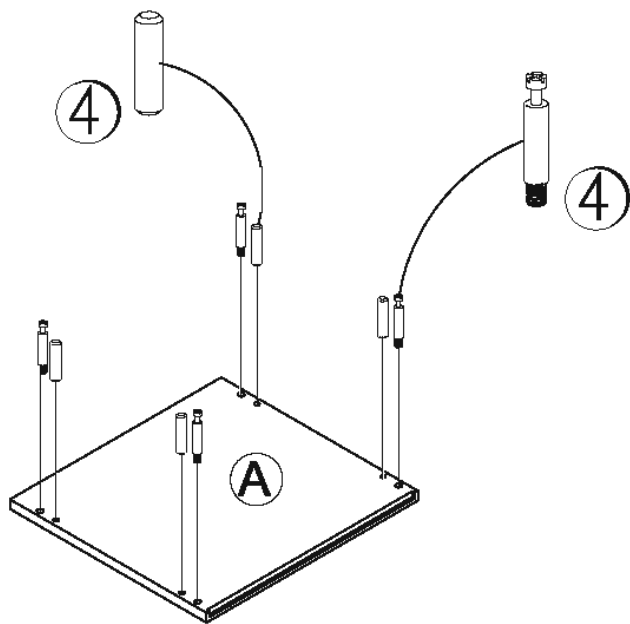

Proper orientation of CAM LOCK  
Orientacion propio del leva de cerradura  
La bonne position des cames

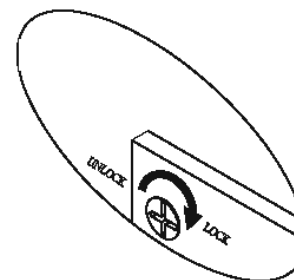

B34951109600

# 4

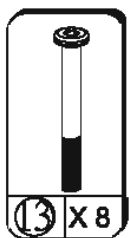
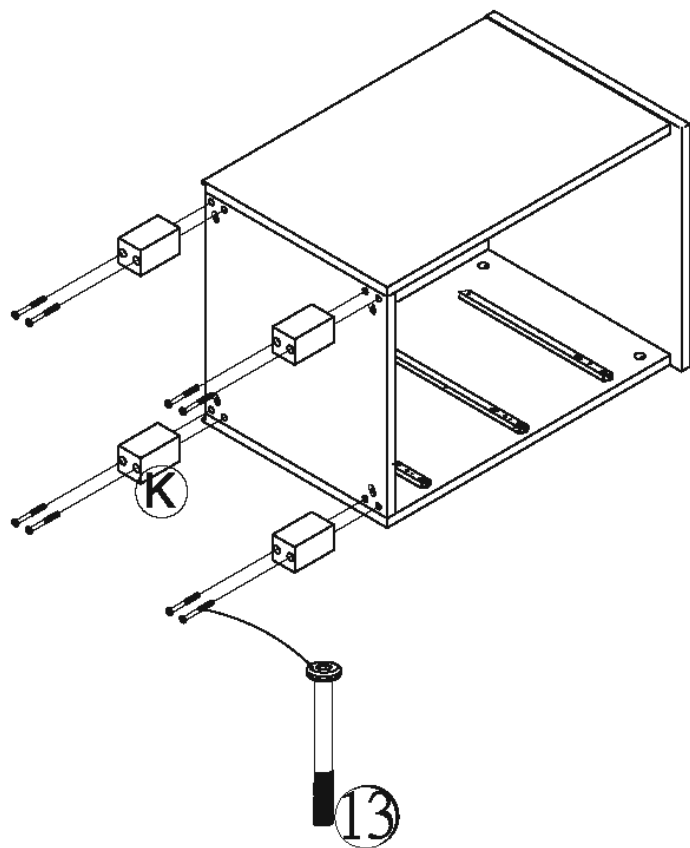

B34951109600

# 5

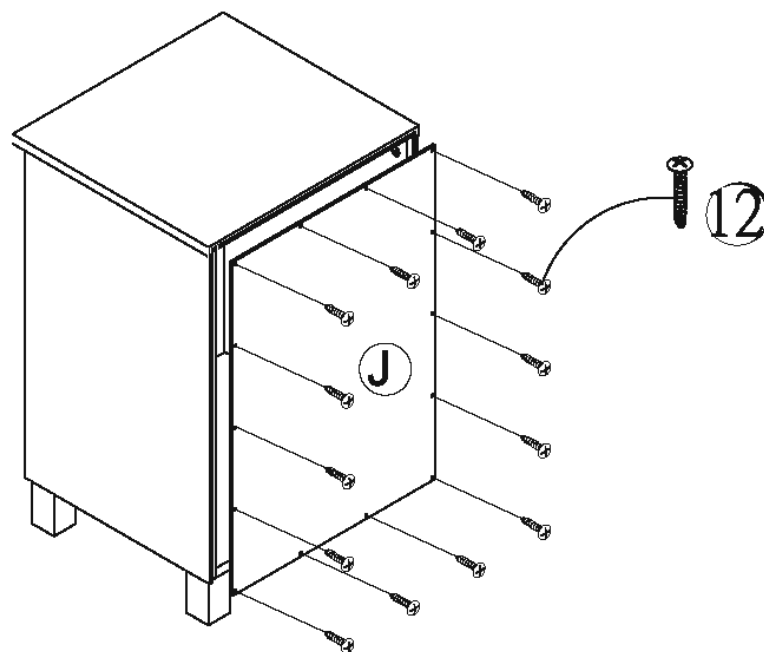

B34951109800

# 6x3

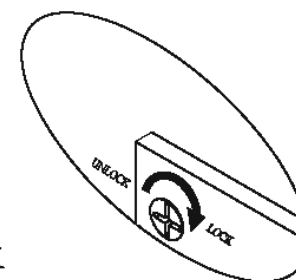
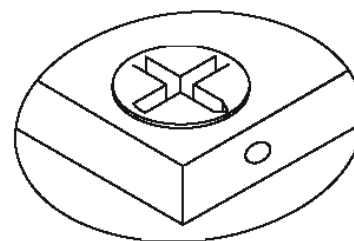
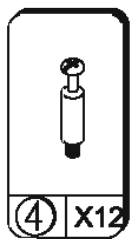
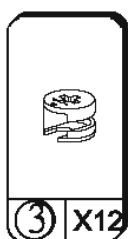
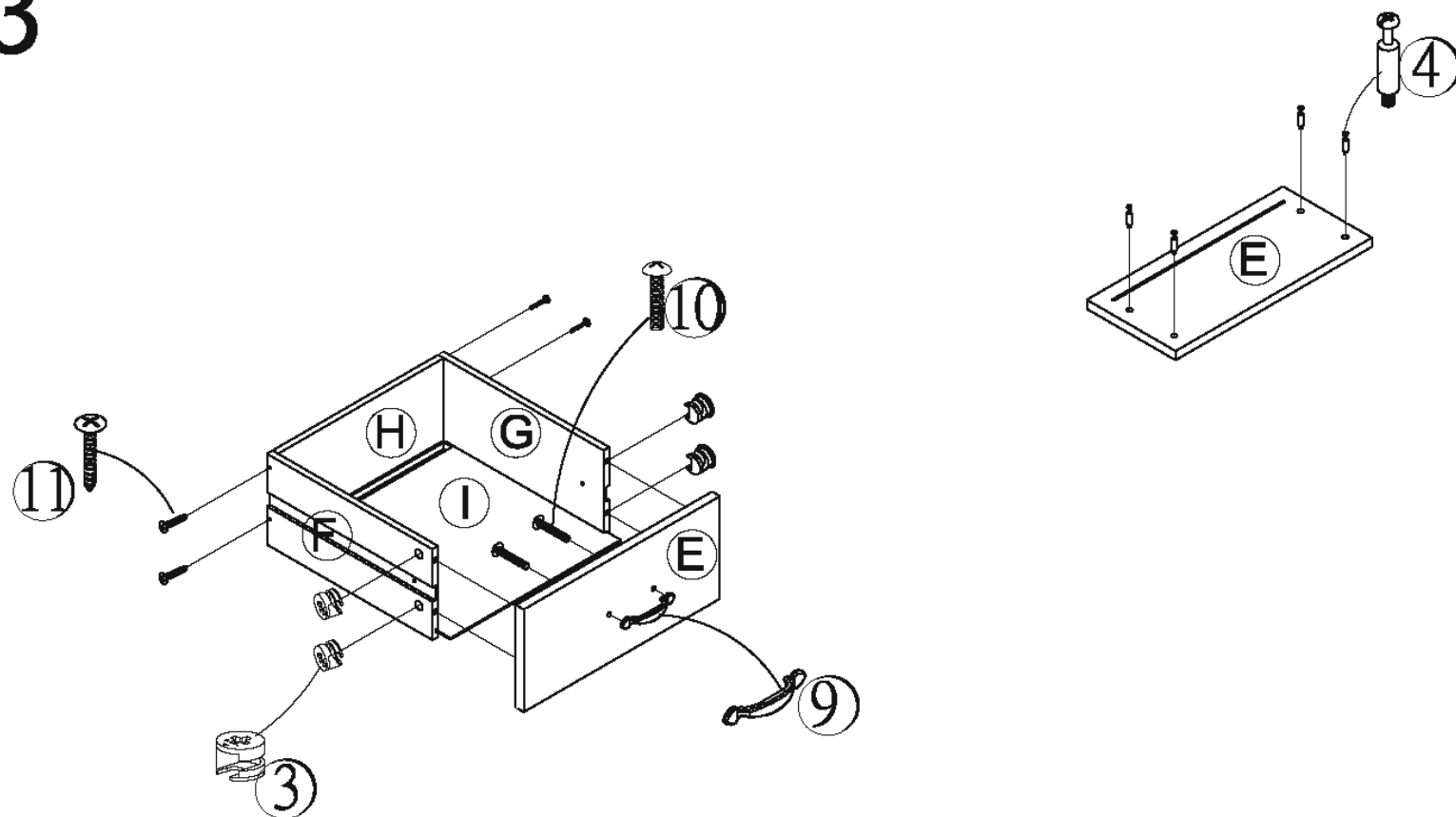

Proper orientation of CAM LOCK  
Orientacion propio del leva de cerradura  
La bonne position des cames



B34951109600

# 7

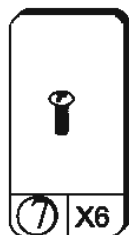
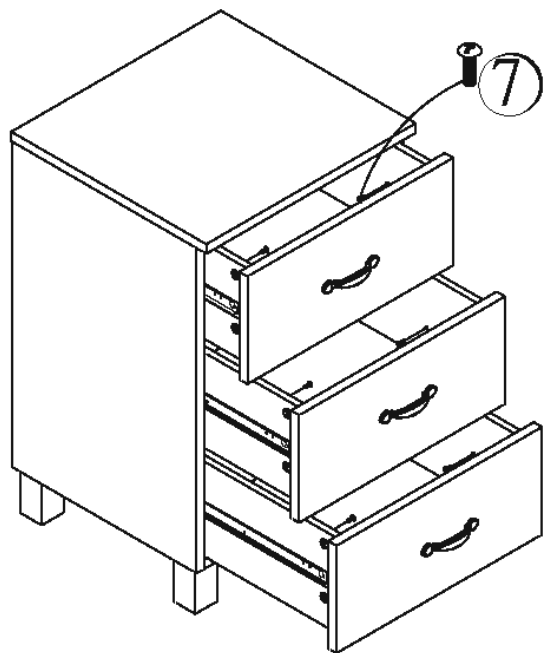

**GREEN OCEAN LOGO Plate:**  
**Placa GREEN OCEAN:**  
**Plaque du logo GREEN OCEAN:**



Place enclosed GREEN OCEAN logo plate on front of unit.  
*Instale la placa GREEN OCEAN adjunta en la parte delantera de su mueble.*  
Placez la plaque du logo GREEN OCEAN ci-incluse devant l'unité.

### *Furniture Touch-Up Marker*

**Directions:** Slowly apply the color to the scratch or light edges. Immediately wipe with soft cloth to remove excess ink. Reapply if necessary. Allow ink to dry and set. Replace cap tightly after each use. Test on an inconspicuous area before use to ensure color match.

**Caution:** FLAMMABLE, made by non-Toxic material

KEEP OUT OF REACH OF CHILDREN

Distributed by Altra Furniture Wright City, MO 63390

[www.altrafurniture.com](http://www.altrafurniture.com) . Made in China

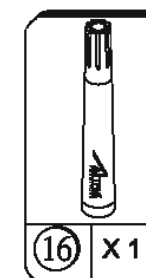

B34951109800

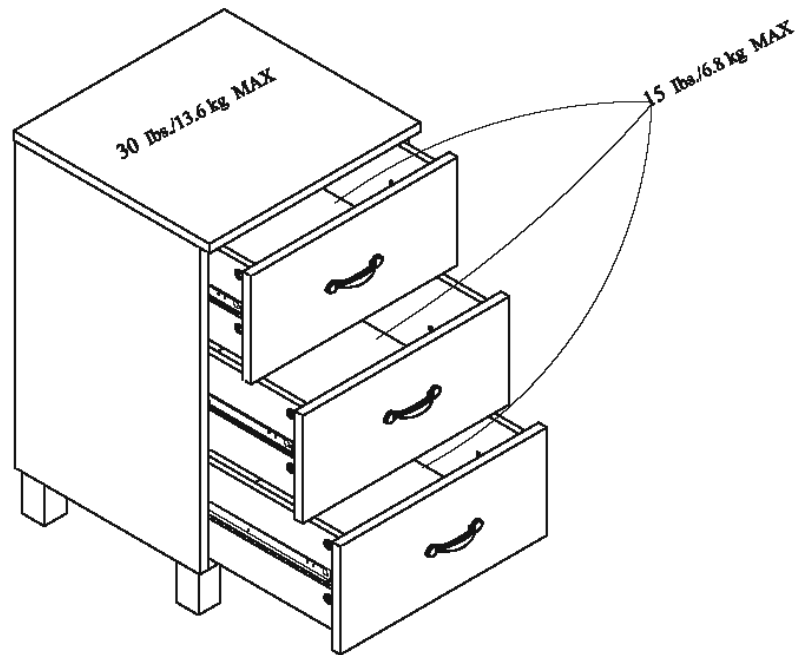

This unit has been designed to support the maximum loads shown. Exceeding these load limits could cause sagging, instability, product collapse, and/or serious injury.

Esta unidad se ha diseñado para apoyar las cargas máximas demostradas. Exceder estos límites de carga podría causar ceder, inestabilidad, derrumbamiento del producto, y/o lesión seria

Cette unité a été conçue pour soutenir les charges maximums montrées. Dépasser ces limites de charge a pu causer le fléchissement, instabilité, effondrement de produit, et/ou dommages sérieux.

**▲ WARNING**

Please make sure that all objects are removed before moving the assembled unit. the unit must be team lifted not dragged or pushed. failure to do so could cause instability, product collapse and/or serious injury.

**▲ ADVERTENCIA**

por favor mueva el mueble cuidadosamente con las ayuda de otra persona. levante y mueva el mueble a su lugar. no lo arrastre o empuje, de lo contrario puede colapsar u ocasionar graves lesiones.

**▲ AVERTISSEMENT**

veuillez vous assurer d'enlever tous les objets sur le meuble avant de le déplacer. ce meuble doit être soulevé en équipe et non traîné ou poussé. sinon le meuble peut devenir instable, s'effondrer, et/ou causer des blessures graves.

**ENJOY YOUR FURNITURE  
DISFRUTA DE TU MUEBLE  
PROFITTEZ BIEN DE VOTRE MOBILIER**



B34951109600